

Technical Information

Flat Cable Crosstalk Testing

The following is a description of two methods Belden uses to test its flat cable for crosstalk. Because these methods are different, the results may be different even when the same type of cable is used in each test. In short, the reader is offered two different tests to determine which cable type has the best crosstalk characteristics. At times, the results of these two test methods do not agree. Therefore, it is best for the reader to determine which method most closely approximates actual cable application and use its results for cable comparisons.

Unbalanced Crosstalk

The unbalanced crosstalk of flat cables is measured as shown in Figure 1. One end of the cable drive is connected through an impedance matching device to a signal generator. The other end of the drive line is terminated in its characteristic impedance. The signal generator is capable of generating square wave pulses of varying leading edge rise times.

A test signal from the signal generator is inserted into the drive line. The cable is connected as follows: Ground-Drive line-Ground-Sample line-Ground or GSG mode. The sample line is also terminated at both ends in its characteristic impedance. The signal at each end of the sample line is measured. The signal at the signal generator end of the sample line is called the near end or reverse crosstalk. The signal at the opposite end of the sample line is called the far end or forward crosstalk. The actual crosstalk figures are given in % and are calculated as follows:

$$\% \text{ Crosstalk} = \frac{\text{Signal in sample line}}{\text{Signal in drive line}} \times 100\%$$

This type of crosstalk test is widely accepted in the flat cable industry. It is a very good method to determine the pulse crosstalk of all types of flat cables connected in the GSG mode. Crosstalk data for Belden flat cables tested using this method is given in the electrical data section of each cable.

Figure 1: Unbalanced Near End Crosstalk

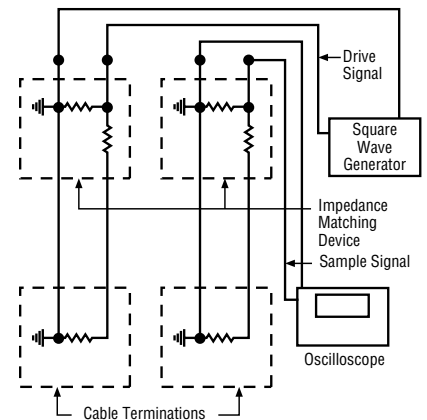

Technical Information

Flat Cable Crosstalk Testing

Balanced Crosstalk

Twisted pair flat cables are not designed to be connected in the GSG mode. These cables provide positive crosstalk reduction over non-twisted pair cables when used in the balanced mode. The balanced crosstalk of twisted pair flat cables is measured as shown in Figure 2. One end of the cable drive pair is connected through a balanced impedance matching transformer to the network analyzer input. The other end of the cable drive pair is terminated in its characteristic impedance. One end of the sample pair is terminated in its characteristic impedance. The other end of the cable sample pair is connected through a balanced impedance matching transformer to the network analyzer output. Because impedance matching transformers are used, none of the wires in the drive or sample line share a common ground. The signal in each line is balanced to ground. For example, one wire of the line will carry the inverse of the signal in the other wire in the same line at any given moment. The signal from the tracking generator is a range of frequencies, typically from 10 MHz to 100 MHz. The signal at each end of the sample line is measured in units of dB of isolation using a spectrum analyzer. The crosstalk results of two cables, one with parallel non-twisted conductors (9L Series) and the other with twisted pair conductors (9V Series) is shown in Figure 3.

In conclusion, it is not the intent of this section to recommend one type of crosstalk testing over another. Rather, it is intended to demonstrate there are different cable types for the different cable applications.

Please choose the crosstalk testing method which most closely approximates your application.

Figure 2: Balanced Near End Crosstalk

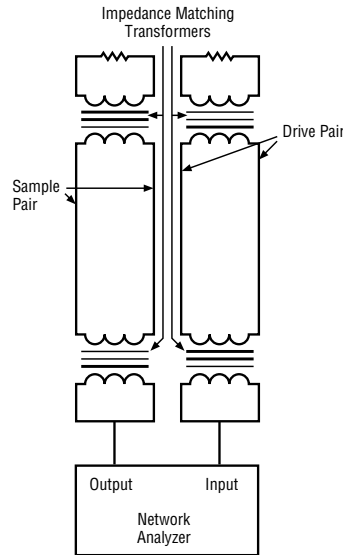

Figure 3: Balanced Crosstalk

