



# HIRSCHMANN

A BELDEN BRAND

## Product Bulletin

PB 1068AG

### Optical Bypass Relay OBR40 from Hirschmann™

With the new optical bypass relay OBR40, Ethernet fiber-optic networks remain operational even if one or more of the switches suffers a power outage. This protection against multiple faults makes it possible to further increase the availability of Ethernet networks.



### **An Internal Switchover Mechanism Ensures that Data Communications Between Neighboring Switches are Unaffected. This Mechanism Functions Independently of the Data Rate or Protocol.**

- The network remains operational even when one or more of the switches suffers a power outage
- The bypass function is guaranteed even when the relay itself is without power
- The ability to schedule the bridging of system components opens up new possibilities for maintenance and servicing

The OBR40 robust optical bypass relay, which can be rail-mounted, makes linear or ring topology fiber-optic Ethernet networks even more reliable. All you have to do is connect it to the uplink ports of a switch. If the supply voltage fails, the bypass function is activated and the switch is bypassed, and it is also possible to use a control contact to trigger the function at will. A stepwise adjustable delay ensures that a previously bridged switch is smoothly returned to the network when the problem has been resolved: the boot process is completed and incoming data packets are dealt with immediately. If a number of switches are each provided with their own "bodyguard," the Ethernet network can survive even multiple failures caused by power outages.

### Applications

The advantages of this optical bypass relay are especially valuable for applications in which parts of the system can operate autonomously. In the event of a local malfunction, data connections to the unaffected parts are maintained so that they can remain fully productive. But high-availability data communication is just one aspect – this relay can do far more than that. In wind parks for example: when the wind gets too strong or when maintenance work is needed, one or more turbines can easily be taken out of the network without affecting the connections of the remainder.

### Your Benefits

If network availability is your top priority, the OBR40 optical bypass relay is the perfect solution. Even if the power fails simultaneously on a number of switches, only the directly affected applications will go down, the remainder of your network – and the major part of your processes – will still be available. You can rely on this even when the OBR40 itself is receiving no power, because the bypass function is effectively activated automatically.



## Optical Bypass Relay OBR40 from Hirschmann™



The OBR40 optical bypass relay enables you to protect Ethernet fiber-optic networks against power outages at one or more switches. It comes with two duplex inputs and outputs that are available for three different types of fiber (multimode 62.5/125  $\mu\text{m}$ , multimode 50/125  $\mu\text{m}$  and single mode 9/125  $\mu\text{m}$ ). It is also possible to use a control contact to trigger the function at will.

A stepwise configurable delay, for intervals up to 75 s, provides for the smooth restarting of switches. This ensures that the switch's boot process can be completed so that incoming data packets can be dealt with immediately. The OBR40 is also remarkable for offering protection rating IP30, an operating temperature range from  $-40^{\circ}\text{C}$  to  $+70^{\circ}\text{C}$ , and a redundant 24 V DC power supply.

LEDS on the front panel indicate the device and network status.

### Benefits at a Glance

- Ethernet fiber-optic networks remain functional in spite of power failures at one or more switches
- Switchover threshold for the supply voltage monitor can be adjusted between 10 V and 60 V
- The bypass function is activated even if the OBR40 itself has no power
- A control contact can be used to trigger the bypass function at will
- Stepwise adjustable delay guarantees smooth reactivation of switches
- Flexible in use, thanks to connections for different types of fiber (multimode 62.5/125  $\mu\text{m}$ , multimode 50/125  $\mu\text{m}$ , single-mode 9/125  $\mu\text{m}$ )
- Protection rating IP30
- Potential-free signal contact
- Extended operating temperature range from  $-40^{\circ}\text{C}$  to  $+70^{\circ}\text{C}$
- Redundant 24 V DC power supply
- LED displays for network status and power supply
- Rail-mounted
- Ideally suitable for all Industrial Ethernet switches from Hirschmann™

This data-transparent optical bypass relay protects applications against multiple failures and is suitable for all data protocols and rates.

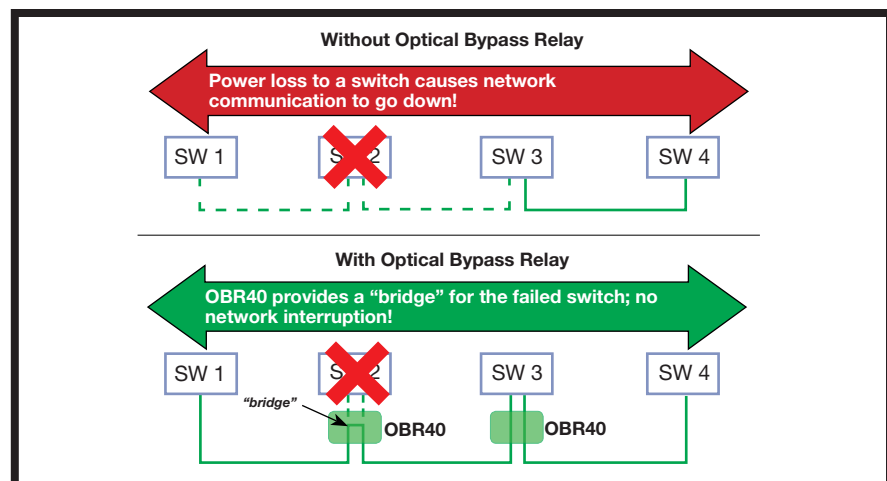

Example of Optical Bypass Relay without and with OBR40 installed



## Technical Information

Product Description			
Type	OBR40-9-LC	OBR40-50-LC	OBR40-62.5-LC
Description	Optical relay for bridging Ethernet switches in the event of power outages. Suitable for all data protocols and rates.		
Port Type and Quantity	4 x LC		
Order No.	942 088-001	942 088-101	942 088-201
Electrical Interfaces			
Power Supply/Signaling Contact	4-pin plug		
Delay	DIL switches		
Switch Voltage	DIL switches		
Optical Interfaces			
Fiber Type	9/125 $\mu\text{m}$	50/125 $\mu\text{m}$	62.5/125 $\mu\text{m}$
Wavelengths	1310 nm and 1550 nm	850 nm and 1310 nm	
Insertion Loss	1.7 dB	1.4 dB	
Crosstalk	> 55 dB		
Return Loss	> 55 dB		
Switching Speed	typ. 4 ms, max. 15 ms		
Power Requirements			
Operating Voltage	10 to 60 V DC		
Power Consumption	2.5 W		
Service			
Diagnostics	LEDs (power 1, power 2, operating status)		
Configuration	Switch threshold adjustable between 10 V and 60 V via DIL switches, Switch-on delay adjustable between 0 s and 75 s via DIL switches		
Redundancy			
Redundancy Functions	Passive bridging of the uplink ports of the attached switch, redundant power feed		
Ambient Conditions			
Operating Temperature	-40°C to +70°C	-30°C to +70°C	
Storage/Transport Temperature	-40°C to +85°C		
MTBF	30 years		
Relative Humidity	10% to 95%		
Mechanical Construction			
Dimensions (WxHxD)	115 x 61 x 113 mm		
Weight	500 g		
Protection Class	IP30		
EMC Interference Immunity			
Electrostatic Discharge (ESD)	EN 61000-4-2, 4 kV contact discharge, 8 kV air discharge		
Electromagnetic Field	EN 61000-4-3, 10 V/m (80 to 1000 MHz), 3 V/m (1.4 to 2 GHz), 1 V/m (2 to 2.7 GHz)		
Fast Transients (Burst)	EN 61000-4-4, 2 kV mains voltage, 1 kV data lines		
Surge Voltage	EN 61000-4-5, 0.5 kV symmetrical and asymmetrical		
Conducted Immunity	EN 61000-4-6, 10 V (150 kHz to 80 MHz)		
EMC Emitted Immunity			
EN 55022	EN 55022 Class B		
Scope of Delivery			
Scope of Delivery	Terminal blocks for power supply and signal contacts, description and users' guide		

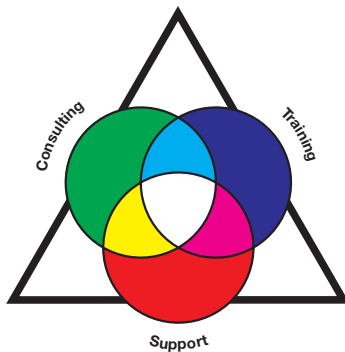

## The Belden® Competence Center

As the complexity of communication and connectivity solutions has increased, so have the requirements for design, implementation and maintenance of these solutions. For users, acquiring and verifying the latest expert knowledge play a decisive role in this. As a reliable partner for end-to-end solutions, Belden offers expert consulting, design, technical support, as well as technology and product training courses from a single source: Belden Competence Center. In addition, we offer you the right qualification for every area of expertise through the world's first certification program for industrial networks. Up-to-date manufacturer's expertise, an international service network and access to external specialists guarantee you the best possible support for products from Belden®, Hirschmann™ and Lumberg Automation™. Irrespective of the technology you use, you can rely on our full support – from the implementation to the optimization of every aspect of daily operations.

### Always Stay Ahead with Belden

In a highly competitive environment, it is crucial to have reliable partners who are able to add value to your business. When it comes to signal transmissions, Belden is the number one solutions provider. We understand your business and want to know your specific challenges and targets to see how effective signal transmission solutions can push you ahead of the competition. By combining the strengths of our three leading brands, Belden®; Hirschmann™; and Lumberg Automation™, we are able to offer the solution you need. Today it may be a single cable, a switch or a connector, thus solving a specific issue; tomorrow it can be a complex range of integrated applications, systems and solutions.

We guarantee the superior performance of your mission-critical systems, even in the most demanding circumstances. If signal transmission is vital to your business, get in touch with the partner that delivers. Be certain. Belden.

Product overview

